

EMBOSS COUNTERSINK ROUND DOWN

TOOL CODE EA

10

ORDERING SPECIFICATIONS

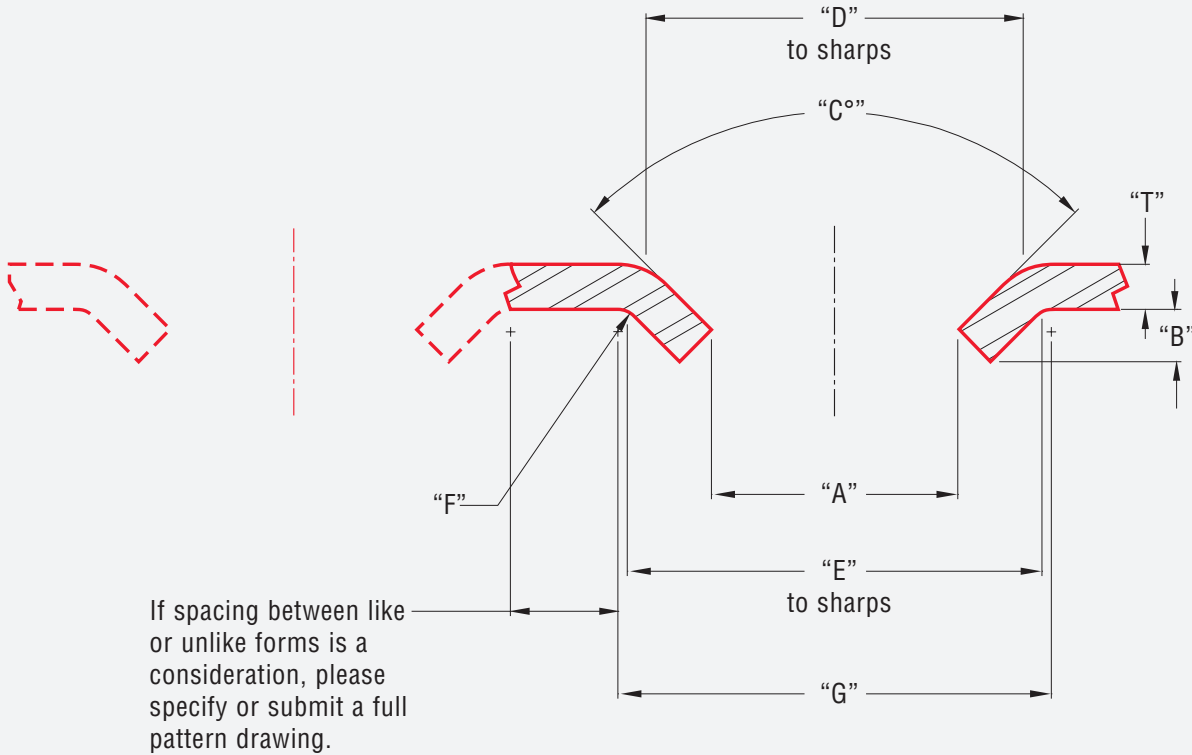

TOOL INFORMATION

Not all of the dimensions shown below are required. Fill in the critical dimensions and a Mate representative will contact you if more information is required.

AØ _____ F _____

B _____ GØ _____

C° _____

DØ _____

EØ _____

GENERAL INFORMATION

Material Type _____

Material Thickness "T" _____

Machine Type _____

Tooling Style _____

Tooling Station _____

Dimensions filled in by _____

Approved By _____

° indicates DEGREES
Ø indicates DIAMETER



Holland Precision Tooling BV
Amsterdamsestraatweg 33 - 1411 AW Naarden
Tel.: 035 - 539 90 90 - info@hptooling.nl

